

MS-3 LASER

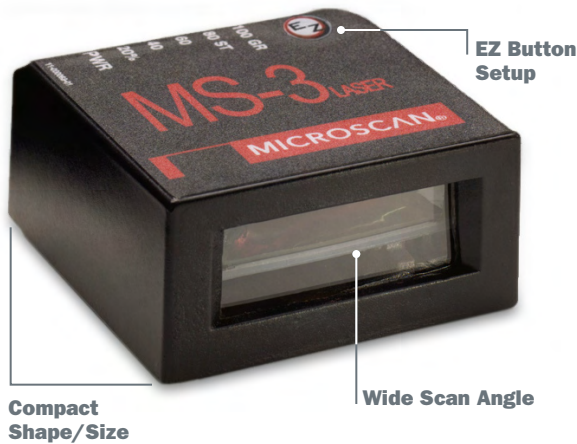

Ultra-Compact Bar Code Scanner

The MS-3 Laser offers the fastest read performance in embedded compact bar code scanners. The wide scan angle of 70 degrees is coupled with ultra-compact size and flexible mounting.

High performance and flexibility make the MS-3 Laser the optimal choice for reliable reading in embedded instruments.

MS-3 Laser: At a Glance

- Decodes/second: up to 1000
- Read Range: 2 to 10" (51 to 254 mm)
- Wide Scan Angle
- IP54 Enclosure



ESP® : Easy Setup Program software provides quick and easy setup and configuration of all Microscan readers.



EZ Button: This performs reader setup and configuration with no computer required.

For more information, visit www.smallscanners.com.

MS-3 Laser: Available Codes

Linear

All Standard



Stacked

MicroPDF



PDF417



RSS



Compact & Lightweight

The 1.75" (44.5 mm) square by .85" (21.6 mm) tall scanner weighs only 2 ounces (57 g) for easy mounting onto robotic equipment or into tight spaces.

High Scan Speed

Adjustable scan speed from 300 up to 1000 decodes per second and Microscan's world-class decode algorithms ensure accurate reading every time.

Wide Scan Angle

The wide scan angle of over 70 degrees and a factory customizable focal point add up to space savings within your system, allowing greater flexibility with positioning.

Visible Indicators

Illuminated LEDs on top of the scanner provide visual confirmation of the scanner performance.

Real-time Controls

The inputs include a trigger signal, a "new master" input, and a programmable input for resetting counters or releasing outputs. The outputs can be configured to activate upon a variety of conditions including matchcode and diagnostic operations.

Application Examples

- Clinical instruments
- Bank ATMs
- Parking kiosks
- Point-of-sale terminals
- Robotics

MICROSCAN®

MS-3 LASER SCANNER SPECIFICATIONS AND OPTIONS

HIGH DENSITY SCAN AREA

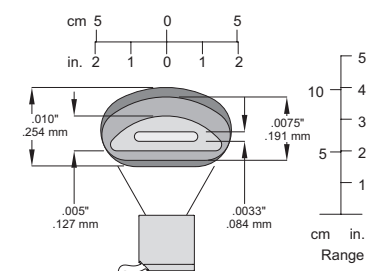

LOW DENSITY SCAN AREA

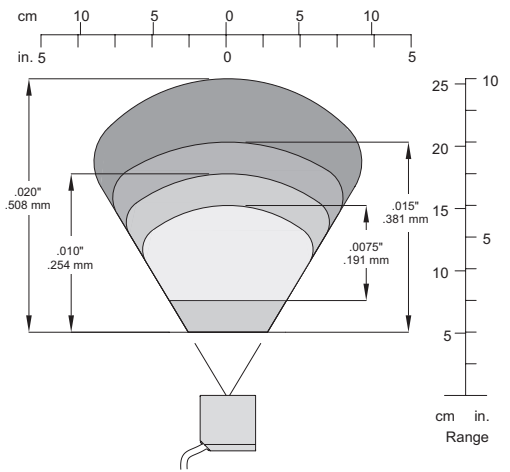

Standard Case, Side

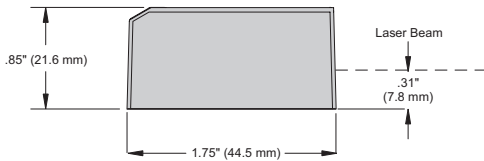

Integral Case, Side

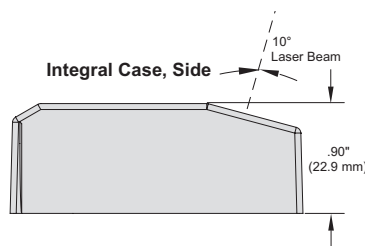

Standard Case, Back

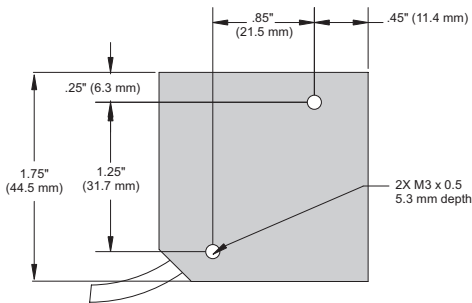

Integral Case, Back

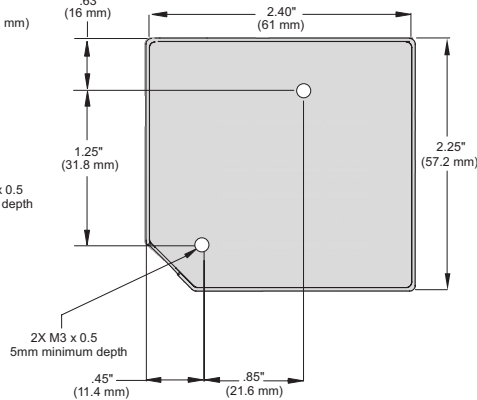

MECHANICAL

Weight (Standard): 2 oz. (57 g)
Weight (Right Angle): 2.8 oz. (87 g)

ENVIRONMENTAL

Housing: IP54 (category 2)
Operating temperature: 0° to 50°C (32° to 122°F)
Storage temperature: -50° to 75°C (-58° to 167°F)
Humidity: Up to 90% (non-condensing)
Operating life: 40,000 hours at 25° C

CE MARK

General immunity for light industry:
 EN 55024: 1998 ITE Immunity Standard
Radiated and conducted emissions of ITE equipment: EN 55022:98 ITE Disturbances

LASER LIGHT

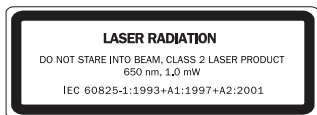

Type: Semiconductor visible laser diode (650 nm nominal)
Safety Class: CDRH Class II, 1.0 mW max.

COMMUNICATION

Interface: RS-232, RS-422/485 (up to 115.2k), Keyboard Wedge, USB

PROTOCOLS

Point-to-Point · Point-to-Point w/RTS/CTS · Point-to-Point w/XON/XOFF · Point-to-Point w/RTS/CTS & XON/XOFF · Polling Mode D · Multidrop · User Defined · User Defined Multidrop · Daisy Chain

SCANNING PARAMETERS

Options: single line, fixed raster
 Scan rate: Adjustable from 300 to 1000 scans/second, default=500
 Scan width angle: >70°
Pitch: ±50°
Skew: ±40°
Label contrast: 25% min. @ 650 nm

HOST CONNECTOR/PIN ASSIGNMENTS

High Density 15 Pin D-sub Socket Connector

Pin No.	Host RS232	Host/Aux RS232	Host RS422/485	In/Out
1	Power +5 VDC			In
2	TxD	TxD	TxD(-)	Out
3	RxD	RxD	RxD(-)	In
4	Power/Signal Ground			
5	NC			
6	RTS	Aux TxD	TxD(+)	Out
7	Output 1 TTL ^a			Out
8	Default configuration ^b			In
9	Trigger			In
10	CTS	Aux RxD	RxD (+)	In
11	Output 3 TTL ^a			Out
12	New Master (NPN)			In
13	Chassis ground ^c			
14	Output 2 TTL ^a			Out
15	NC			

- a. Can sink 10 mA and source 2 mA.
 b. The default is activated by connecting pin 8 to ground pin 4.
 c. Chassis ground: Used to connect chassis body to earth ground only. Not to be used as power or signal return.

CONNECTOR

Type: 3 ft. cable terminated with High Density 15-pin D-Sub socket connector

ELECTRICAL

Power: 5 VDC +/- 5 %, 200 mV p-p max. ripple, 260 mA @ 5 VDC (typ.)

DISCRETE I/O

Trigger Input: 3 to 24V rated (1 mA @ 5 VDC)

New Master: 3 to 24V rated (1 mA @ 5 VDC)

Outputs (1, 2, 3): 5V TTL compatible, can sink 10 mA and source 2mA

SYMBOLOGIES

Code 39, Codabar, Code 128, I 2 of 5, Code 93, UPC/EAN, Pharmacode, PDF417 (option)

INDICATORS

Beeper: Good read, Match/Mismatch, Noread,
On/Off LEDs: 1 status, 1 power, 5 read performance (representing percentage of good decodes)

READ RANGES

Narrow-bar-width	Read Range
HIGH DENSITY	
.0033" (.084 mm)	2.3" to 2.6" (58 to 66 mm)
.005" (.127 mm)	2" to 3.1" (51 to 79 mm)
.0075" (.191 mm)	1.7" to 3.7" (43 to 94 mm)
.010" (.254 mm)	1.5" to 4" (38 to 102 mm)
LOW DENSITY	
.0075" (.191 mm)	3" to 6" (76 to 152 mm)
.010" (.254 mm)	2" to 7" (51 to 178 mm)
.015" (.381 mm)	2" to 8" (51 to 203 mm)
.020" (.508 mm)	2" to 10" (51 to 254 mm)

Note: For Right Angle option, subtract 0.6" (15 mm) from read range. Read ranges are based upon optimal scan speed for specific symbol density.

SAFETY CERTIFICATIONS DESIGNED FOR CDRH, FCC, UL/cUL, CE, BSMI



ISO 9001:2000
CERTIFIED QMS

ROHS/WEEE COMPLIANT

ISO CERTIFICATION

Issued by RWTÜV, USA Inc.
 ISO 9001:2000 – Cert No. 03-1212

©2006 Microscan Systems, Inc. 09/06 Rev. A
 Read Range and other performance data is determined using high quality Grade A symbols per ISO/IEC 15415 and ISO/IEC 15416 in a 25°C environment. For application-specific Read Range results, testing should be performed with symbols used in the actual application. Microscan Applications Engineering is available to assist with evaluations. Results may vary depending on symbol quality. Warranty—One year limited warranty on parts and labor. Extended warranty available.

MICROSCAN®

Microscan Systems, Inc.

Tel 425 226 5700 / 800 251 7711
 Fax 425 226 8250

Microscan Europe

Tel 31 172 423360 / Fax 31 172 423366

Microscan Asia Pacific R.O.

Tel 65 6846 1214 / Fax 65 6846 4641

Part of a full range of sales tools available from our website:

www.microscan.com

E-mail: info@microscan.com

Tech Support: helpdesk@microscan.com